

User's Manual

TA300

DIESEL ENGINE TACHOMETER

Table of contents.

1. Safety Rules	Page 1
2. Technical Specifications	Page 2
2.1 General specifications	Page 2
2.2 Electrical Specifications	Page 2
3. Operation	Page 3
3.1 Instrument description	Page 3
3.2 LCD Display	Page 3
3.3 Buttons description and operation	Page 4
3.4 Measurement procedures	Page 5
3.5 Additional functions	Page 6
4. Application information	Page 8
4.1 Using the piezoelectric sensor	Page 8
4.2 Troubleshooting	Page 8
5. Maintenance	Page 10
5.1 Battery replacement	Page 10
5.2 Cleaning	Page 10
6. Warranty	Page 10

1. SAFETY RULES

- This instrument is designed for indoor use at temperatures between 32° and 104° F (0°C and 40°C) and altitudes up to 6500 ft (2,000 meters).
- To ensure that the instrument is used safely, follow all safety and operating instructions in this operation manual. If the instrument is not used as described in this operation manual, the safety features of this instrument may be impaired.
- Do not use the instrument if the instrument, the cables or the piezoelectric pickup, or if you suspect that the instrument is not operating properly.
- When using the instrument, keep away from moving parts (fan, drive belts, etc) and hot objects (exhaust pipes, muffler , catalytic converter, etc), to avoid personal injuries and damage to the instrument, the cable or piezoelectric pickup.
- Do not connect or apply more than 42 VDC or any AC current directly to the connectors or the piezoelectric pickup.
- At all times, to avoid electrical shock, use CAUTION when working with electrical circuits above 60V DC or 25V AC rms. Such voltages pose a shock hazard.
- Do not operate this instrument without the rubber holster or the battery cover off.
- To avoid electrical shock or damage to the instrument, do not exceed the specified input limits.

Exceeding the limits listed above when using this apparatus, or not observing the precautions listed above can expose you to physical injury and permanently damage your instrument and/or parts and components of the vehicle under test.

'SmarTach', 'V Ready, and 'GTC' are trademarks of General Technologies Corp.

2. TECHNICAL SPECIFICATIONS

2.1 General Specifications

Display:	LCD 4½ digit main measurement, 2 x 3½ digit for maximum and minimum measurements, indicators for low battery, number of cycles and units.
Update rate:	3 per second (for LCD).
Engine system Comp.	Fuel injection pump with lines for each cylinder.
Engine cycles:	2 and 4 cycles.
Fuel injection line:	Up to 9 mm dia. (Depending on piezoelectric pickup used)
Power:	9 Volt battery, type MN1604.
Auto power off:	Automatically powers off after 1 minute of no operation.
Battery life:	Approximately. 30 hours. (w/alkaline battery).
Cable length:	6' (1.8 m)
Dimensions:	6" x 4" x 1.5" (158 x 100 x 37 mm) without cable.
Weight:	Approximately. 14 Oz. or 406 g. (Including battery).
Included accessories:	Padded hard carrying case, user's manual, rubber holster and 1 x 9 Volt alkaline battery.

2.2 Electrical Specifications

- The specifications below are typical at 23° C, and will vary slightly from device to device, and with temperature. The input voltage should not exceed the indicated maximum values, to prevent personal injury or damage to the instrument.

Function	Measurement Range	Accuracy/Repetitivity	Input Characteristics
RPM	100 to 19999 RPM 2 and 4 cycles	Accuracy: 0.1% ± 1 LSD	Input Impedance: 2 MΩ minimum + 100 pF (Max). Input Protection: ± 42 VDC Max.
Sensitivity Adjust	Signal sensitivity adjustable from 1 to 10	Default setting: 5	
Trigger Level Adjust	Trigger level adjustable from 20% to 80% of peak input signal	Default setting: 50%	

3. OPERATION

3.1 Instrument Description

- 1) Protective rubber holster
- 2) LCD Display
- 3) Power ON/OFF / Reset button
- 4) Sensitivity Increase button
- 5) Number of Cycles button
- 6) Sensitivity Decrease button
- 7) Trigger Level Adjust function button
- 8) Piezoelectric pickup
- 9) Ground clip

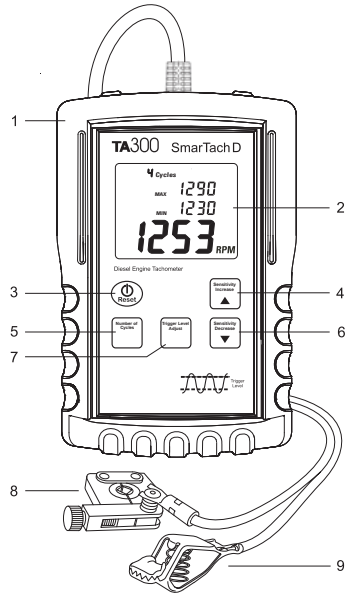

Fig. 1 - Instrument description

3.2 LCD Display

3.2.1 LCD Display description

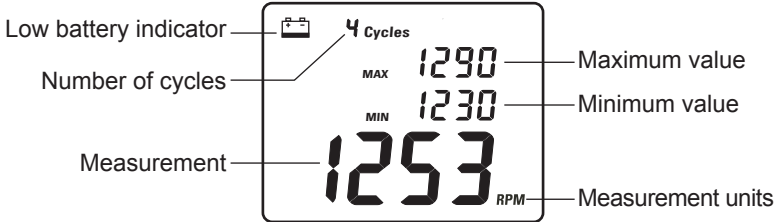

Fig. 2 - LCD Display



Low battery indicator

- This message warns the battery voltage is below the minimum recommended and it needs to be replaced with a new battery.
- If the battery voltage is low, but still allows for the operation of the instrument, the low battery indicator will turn and stay on until the battery is replaced with a new one.

Note: If the unit turns off immediately after being turned on, it indicates that battery voltage is below the absolute minimum, and the battery should be replaced to prevent malfunction.

MAX - Maximum reading

- Holds and displays the maximum value of the measurements, with the last digit rounded to '0'. The maximum measurement is automatically reset when turning the unit off or manually by momentarily pressing the 'Power On/Off / Reset' button.

MIN - Minimum reading

- Holds and displays the minimum value of the measurements, with the last digit rounded to '0'. The minimum value is automatically reset when turning the unit off or manually by momentarily pressing the 'Power On/Off / Reset' button.

Cycles - Number of Cycles

- Displays the selected number of cycles: 2 and 4.

Measurement units

- Displays the measurement unit: RPM

Measurement reading

- Displays the measurement.

3.3 Buttons description and operation

3.3.1 Power ON/OFF and Reset



- When the instrument is OFF, to turn it ON press the 'Power ON/OFF / Reset' button until the unit turns on (in approximately 1 second).
- When the instrument is ON, to turn it OFF press and hold the 'Power ON/OFF / Reset' button until the display turns off (in approximately 3 seconds).
- When the instrument is ON, press momentarily the 'Power ON/OFF / Reset' button to reset the Maximum and Minimum values.

Note: To extend battery life, the TA300 will automatically turn off after 1 minute of being idle (i.e. no button pressed and no input signal). Turning the unit off manually, when not in use will prolong battery life.

3.3.2 Number of cycles



- Press the 'Number of Cycles' button to select the number of cycles for the engine under measurement. Each time the button is pressed the number of cycles will change between 2 cycles and 4 cycles. The selected setting will show on the display.

3.3.3 Trigger Level Adjust



- Press and hold the 'Trigger Level Adjust' button to enable the trigger level (threshold) adjust function. After this button is pressed, the display will show the current trigger level (50% is the default setting), and the trigger level can be adjusted by using the 'Sensitivity Increase' or 'Sensitivity Decrease' buttons to increase or decrease it.

3.3.4 Sensitivity Increase and Decrease buttons



- The first time the 'Sensitivity Increase' button is pressed, the display will show the sensitivity setting, and each time the button is pressed again it will increase the signal sensitivity of the TA300. A few seconds after the button is released the display will resume to show maximum and minimum readings.



- The first time the 'Sensitivity Decrease' button is pressed, the display will show the sensitivity setting, each time the button is pressed again it will decrease the signal sensitivity of the TA300. A few seconds after the button is released the display will resume to show maximum and minimum readings.

3.4 Measurement Procedures

CAUTION

To avoid personal injuries and damage to the instrument carefully inspect the fuel injection lines and fuel pump for damage or leaks, and avoid using this instrument in case any damage or leaks are found. Never touch the piezoelectric sensor during a test. Wear insulating gloves when working around high voltage, and hot parts, and keep away from moving parts (fan, drive belts, etc) and hot objects (exhaust manifold and pipes, muffler, catalytic converter, etc.)

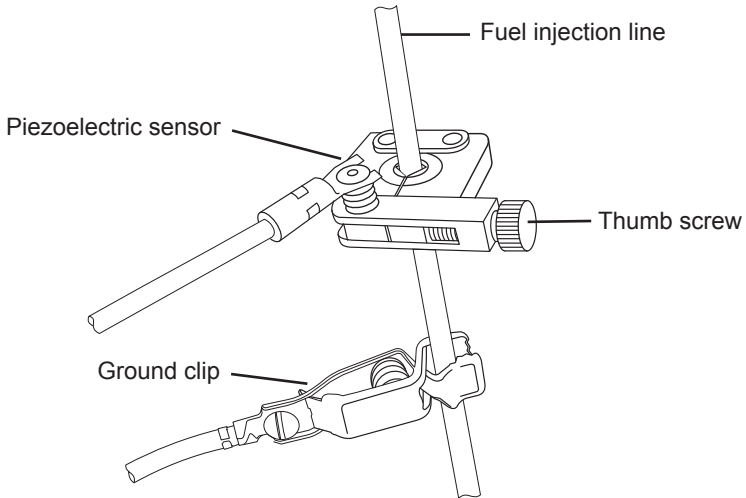



Fig. 3 - Piezoelectric sensor and ground clip on fuel line

- 1- Clamp the piezoelectric pickup onto a clean unpainted section of any diesel injection pipe. Do not over tighten the thumb screw (see Fig. 3)
- 2- Clip the alligator ground clip onto a clean unpainted section of the same injection line.
- 3- Connect the forked terminal to the piezoelectric pickup.
- 4- Turn the instrument on.
- 5- If necessary change the number of cycles to match the engine under measurement by pressing the  (Number of cycles) button repeatedly until the display shows the correct setting.
- 4- Start the diesel engine.
- 6- Read the RPM on the display.

3.5 Additional functions

3.5.1 Minimum and Maximum functions

The TA300 holds the maximum and minimum values of the measurement on the display.

- The maximum and minimum values are reset upon turning the TA300 power on, or by momentarily pressing the  (Power On/Off and Reset) button.
- The maximum and minimum values will be shown with the last digit rounded to 0.

3.5.2 Sensitivity Adjust function

The TA300 allows the user to adjust the level of signal sensitivity it can detect, in order to match a wide variety of fuel pressures and fuel lines characteristics.

To use the Sensitivity Adjust function:

- 1-Turn the instrument on.
- 2-To perform adjustments of the signal sensitivity while performing actual measurements, follow the procedure as described in '3.4 Measurement procedures'.
- 4-The first time the 'Sensitivity Increase' or the 'Sensitivity Decrease' button is pressed, the display will show the sensitivity setting (see Fig. 4), and each time the button is pressed again it will increase or decrease the signal sensitivity. A few seconds after the button is released the display will return to show maximum and minimum readings.

Notes:

- Adjusting the signal sensitivity of the TA300 while performing RPM measurements, provides quick feedback on how this setting affects the response of the TA300 in any given situation.
- Signal sensitivity can be adjusted between 1 and 10. The factory calibration value is 5.
- The lower the value of the sensitivity setting the bigger the signal input needs to be for detection by the TA300, and conversely higher sensitivity settings can detect smaller signals input.
- The values set by using the Sensitivity Adjust function are stored in internal memory, and will be retained even if the instrument is powered off, the battery is depleted or removed.

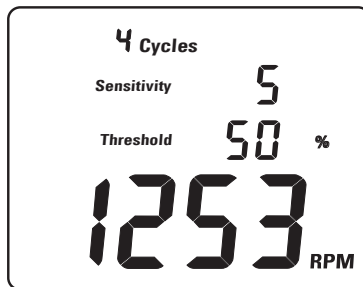





Fig. 4 - Example of display when in Sensitivity or Trigger Level Adjust mode

3.5.3 Trigger Level Adjust function

The TA300 also allows the user to adjust the trigger level (threshold) it uses to measure RPM from the signal it receives from the piezoelectric pickup. This feature can be used to compensate for excessive noise in the signal generated by vibration, electromagnetic interference or particular characteristics of fuel pressure, injection patterns and fuel lines.

To use the Sensitivity Adjust function:

- 1-Turn the instrument on.
- 2-To perform adjustments of the trigger level while performing actual measurements, follow the procedure as described in '3.4 Measurement procedures'.
- 3-Press and hold the  (Trigger Level Adjust) button until the minimum reading in the display is replaced by the word "Threshold" followed by a set level number and then a '%' sign (see Fig. 4).
- 4- While holding the  (Trigger Level Adjust) button pressed, use the  (Sensitivity Adjust increase) or  (Sensitivity Adjust decrease) buttons to adjust the % value.

Notes:

- Adjusting the trigger level of the TA300 while performing RPM measurements, provides quick feedback on how this setting affects the response of the TA300 in any given situation.
- The trigger level can be adjusted between 20% and 80%. The default value for the trigger level is 50%.
- For example, if the trigger level is set to 70%, the TA300 will register an engine cycle when the signal level from the piezoelectric pickup reaches or exceeds 70% of the maximum signal.
- Higher trigger levels increases the noise rejection, and lower trigger level will help in measuring RPM when dealing with inconsistent injection pulses. For most cases the default 50% level is the optimal value.
- The values set by using the Trigger Level Adjust function are stored in internal memory, and will be retained even if the instrument is powered off, the battery is depleted or is removed.

4. APPLICATION INFORMATION

4.1 Using the piezoelectric pickup

Important

The piezoelectric pickup is constructed with a special piezoelectric ceramic material and it can be easily damaged by impacts or if excessive pressure is applied.

- 1-For the piezoelectric pickup to work, it requires that a good electrical connection be established between the center part of the pickup, and the ground clip. This can be achieved in two ways:
 - Fit the piezoelectric pickup to a clean unpainted section of an injection line. Then connect the ground clip to that same clean section of the injection line as shown in Fig. 3. or to a convenient ground in the engine. If necessary scrape and sandpaper the line in order to expose the metal surface.
 - If you do not wish to scrape the fuel line, you could tightly wrap a piece of aluminum foil around the pipe and clamp the piezoelectric pickup over this foil. Make the foil wrap long enough to allow placing of the ground clip on the same piece of foil. Use of aluminum foil will often fix problems due to bad electrical connections between the piezoelectric pickup and the injection pipe and ground clip.
- 2- Do not over tighten the clamp. Use of excessive force or tools such as pliers to tighten the clamp will result in damage to the piezoelectric pickup and void the guarantee.
- 3-If not already connected, locate the forked terminal at the end of the red wire (near to the alligator ground clip) and push it under the flat head of the connector pin at the corner of the piezoelectric pickup. This connector pin is the one with a coil spring. You will see that this spring presses a conical washer against the flat pin head. The forked terminal must be inserted between this washer and the flat pin head. Hook up is now complete.

4.2 Troubleshooting

The main factors that may cause unstable, erroneous or in some cases prevent the TA300 from obtaining a measurement at all are:

- Poor electrical contact between the center of the piezoelectric pickup and the ground clip.
- Engine/fuel line vibration.
- Weak signal due to the characteristics of the fuel line or the fuel injection pump.

4.2.1 Poor electrical contact

Please refer to '4.1 Using the piezoelectric pickup' for detailed instructions on how to use the piezoelectirc pickup.

4.2.2 Engine/fuel line vibration

The piezoelectric pickup is specially designed to detect the expansion of the fuel line cause by the pulses of pressure generated by the fuel when injected into the cylinder. However under some conditions the vibration of the engine and fuel line may cause an excessive amount of noise in the signal, in which cases the TA300 may not recognize the signal and generate incorrect RPM readings or no reading at all.

Possible solutions:

- Use the Trigger Level Adjust function to change the trigger level (threshold) until a stable RPM is obtained.
- Sometimes the vibration noise may be caused or magnified by the minute 'jerking' of the cable connecting to the piezoelectric pickup to the TA300, and providing some strain relief may be of help in obtaining RPM readings. To provide strain relief to the piezoelectric pickup, attach the red wire (which is connected to the pickup) to the same fuel line using electrical tape or a cable tie, as shown in Fig 5.

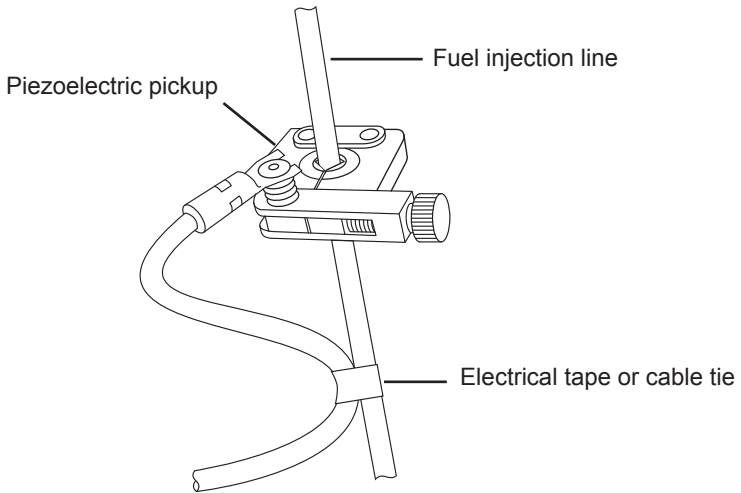

Fig. 5 - Strain relief setup for piezoelectric pickup

4.2.3 Weak signal due to the characteristics fuel line or fuel injection pump

There are many factors that may contribute to the piezoelectric pickup not being able to generate a signal (pulse) strong enough for the TA300 to detect. These situations may cause low, slow or inconsistent built up of fuel pressure in the fuel line. Some common causes are listed below:

- Leaky, dirty or damaged fuel injectors.
- Damaged fuel pump.
- Very low cylinder pressure.
- Presence of air in the fuel line.

Possible solutions:

- Change the position of the piezoelectric pickup in the fuel line.
- Place of the piezoelectric pickup to a different fuel line.
- Change the signal sensitivity of the TA300 using the Sensitivity Adjust function (refer to section '3.5.2 Sensitivity Adjust function' for detailed instructions) until a reading is obtained. If the RPM readings are erroneous or unstable proceed to adjust the trigger level (refer to section '3.5.3 Trigger Level Adjust function' for detailed instructions) until a stable RPM is obtained..

5. MAINTENANCE

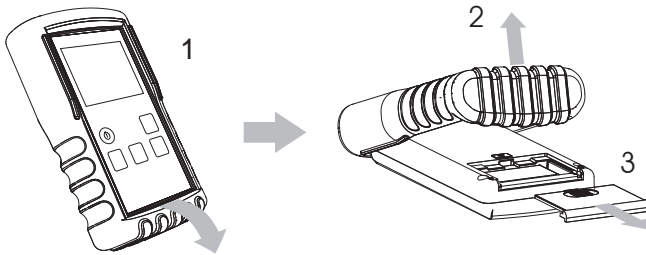

Fig 6 - Battery replacement

5.1 Battery replacement

- 1-Release the rubber holster from plastic enclosure by pulling from the bottom of the holster as shown in the illustration (Fig. 6).
- 2-Push the rubber holster forward until the battery compartment cover is exposed.
- 3-Slide open battery cover located at the back of the unit.
- 4-Connect the new battery observing the polarity of the battery connectors.
- 5-Replace battery cover and rubber holster.
- 4-Press the 'Power On/Off / Reset' button on the TA300 until the display turns on. If the display does not turn on, check the battery polarity and reinstall if necessary.
- 5-To turn the unit off, press and hold the 'Power On/Off / Reset' button again the displays turn off.

5.2 Cleaning

Keep the instrument in its carrying case when not in use and do not subject it to dampness or severe heat or cold. Do not use the instrument in the rain, if it should accidentally get wet, dry it off with a clean paper towel before storing it away.

Protect the unit from contact with any solvents. Never clean with a solvent or petroleum based medium such as gasoline, as these chemicals may attack the plastic parts and cause permanent damage. Never use an abrasive cleaner. Cleaning should be limited to wiping with a clean damp paper towel and a small amount of soap if required. Dry the unit thoroughly after any cleaning.

The unit is a sealed instrument and contains no user serviceable parts other than the battery, which can be replaced by opening the drawer on the back of the unit. Opening other parts of the unit will void the warranty.

6. WARRANTY

With the exception of the battery, this instrument is warranted against defects of material or workmanship which develop within a period of one (1) year following the date of purchase by the original owner. For details see Standard Warranty Information on our web page at www.gtc.ca or you may request a printed copy.

To visit our website, scan the QR code below with your smart phone.



Or type this URL in your browser:

www.gtc.ca

GTC
General Technologies Corp

#121 - 7350 72nd Street
Delta, BC
Canada V4G 1H9

Tel: (604) 952-6699
Fax: (604) 952-6690
email: info@gtc.ca