

User's Manual

TA500

MULTISYSTEM ENGINE
ANALYZER

Table of contents.

1. Safety Rules	Page 1
2. Technical Specifications	Page 2
2.1 General specifications	Page 2
2.2 Electrical specifications	Page 2
3. Operation	Page 3
3.1 Instrument description	Page 3
3.2 LCD Display	Page 3
3.3 Buttons description and operation	Page 5
3.4 Measurement procedures	Page 7
3.5 Additional functions	Page 10
4. Application information	Page 12
4.1 Taking measurements	Page 12
4.2 Diagnostic using spark KV and burn time	Page 12
4.3 Common causes of long burn time or low spark KV	Page 12
4.4 Common causes of short burn time or high spark KV	Page 13
5. Maintenance	Page 14
5.1 Battery replacement	Page 14
5.2 Cleaning	Page 14
6. Warranty	Page 14

1. SAFETY RULES

- This instrument is designed for indoor use at temperatures between 32° and 104° F (0°C and 40°C) and altitudes up to 6500 ft (2,000 meters).
- To ensure that the instrument is used safely, follow all safety and operating instructions in this operation manual. If the instrument is not used as described in this operation manual, the safety features of this instrument may be impaired.
- Do not use the instrument if the instrument, the capacitive pick-up or the flexible probe looks damaged, or if you suspect that the instrument is not operating properly.
- When using the instrument, keep away from moving parts (fan, drive belts, etc) and hot objects (exhaust pipes, muffler , catalytic converter, etc), to avoid personal injuries and damage to the instrument, the capacitive pick-up or the flexible probe.
- Do not connect or apply more than 42 VDC or any AC current directly to the capacitive pick-up or the flexible probe.
- At all times, to avoid electrical shock, use CAUTION when working with electrical circuits above 60V DC or 25V AC rms. Such voltages pose a shock hazard.
- Do not operate this instrument with the battery cover off.
- To avoid electrical shock or damage to the instrument, do not exceed the specified input limits.

Exceeding the limits listed above when using this apparatus, or not observing the precautions listed above can expose you to physical injury and permanently damage your instrument and/or parts and components of the vehicle under test.

2. TECHNICAL SPECIFICATIONS

2.1 General Specifications

Display:	LCD 4½ digits main display, 2 x 3½ digits for secondary displays, indicators for low battery, number of cycles, ignition system, functions and measurement units.
Update rate:	3 per second (for LCD).
Ignition system comp.:	Coil on plug, coil near plug, DIS, conventional and magneto.
Engine cycles:	2 and 4 cycles and DIS (distributorless ignition system).
Power:	9 Volt battery, type MN1604.
Auto power off:	Automatically powers off after 3 min. of no operation.
Battery life:	Approximately 20 hours (w/alkaline battery).
Probe length:	13.5" (34 cm) Including capacitive pick-up.
Dimensions:	6" x 4" x 1.5" (158 x 100 x 37 mm) without antenna.
Weight:	Approximately 14 Oz. or 406 g. (Including battery).
Included accessories:	Padded hard carrying case, user's manual, rubber holster and 1 x 9 Volt alkaline battery.

2.2 Electrical Specifications

- The specifications below are typical at 23° C, and will vary slightly from device to device, and with temperature. The input voltage should not exceed the indicated maximum values, to prevent personal injury or damage to the instrument.

Function	Measurement Range	Accuracy/Repetitivity	Input Characteristics
RPM	200 to 19999 RPM 2 and 4 cycles and DIS	Accuracy: 0.5% ± 1 LSD	Input Impedance: 100KΩ + 1.5 nF (Minimum). Input Protection: ± 42 VDC Max.
Spark KV	0 to 50 Kv	Repeatability: 3% ± 1 LSD	
Spark burn time	0 to 10 ms	Accuracy: ± 0.1 ms	

3. OPERATION

3.1 Instrument Description

- 1) Capacitive pick-up
- 2) Flexible probe
- 3) Protective rubber holster
- 4) LCD Display
- 5) Power ON/OFF / Reset button
- 6) Secondary Function / Capture button
- 7) Ignition System button
- 8) Main Function / Calibrate button
- 9) Engine Cycles button

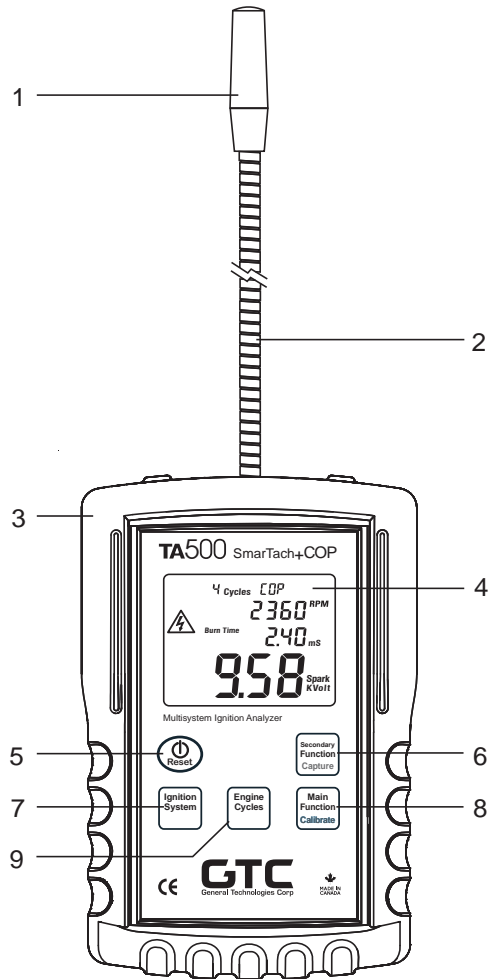

Fig. 1 - Instrument description

3.2 LCD Display

3.2.1 LCD Display description

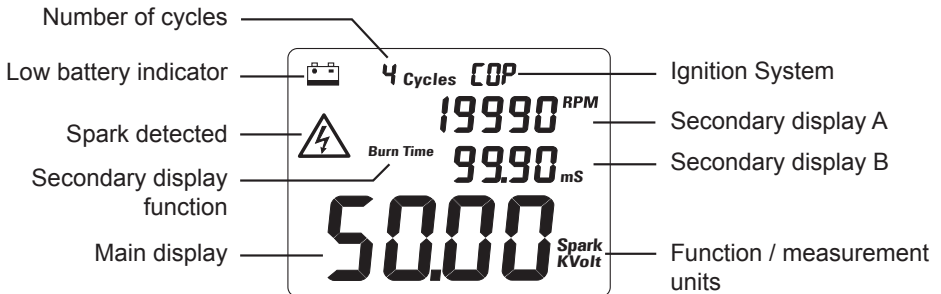



Fig. 2 - LCD Display

3.2.2 Low battery indicator

The low battery symbol '  ' indicates the battery voltage is below the minimum recommended and it needs to be replaced with a new battery.

Notes:

- If the battery voltage is low, but still allows for the operation of the instrument, the low battery indicator will turn and stay on until the battery is replaced with a new one.
- If the unit turns off immediately after being turned on, it indicates that battery voltage is below the absolute minimum, and the battery should be replaced to prevent malfunction.

3.2.3 Number of Cycles

Displays the number of cycles (strokes) selected: 2, 4 or DIS.

3.2.3 Ignition System

Displays the ignition system selected for the measurement: 'SPW' for Spark Plug Wire, and 'COP' for Coil on Plug and Coil near Plug

3.2.4 Spark Detected

A flashing high voltage symbol '  ' indicates that sparks are being detected in the ignition system.

3.2.5 Secondary display A

Depending on the setting chosen by pressing the 'Secondary Function / Capture' button, it displays maximum readings, RPM or spark KVolt with measurement units and/or function selected.

3.2.6 Secondary display B

Depending on the setting chosen by pressing the 'Secondary Function / Capture' button, it displays minimum readings, RPM or spark burn time with measurement units and/or function selected.

Note: RPM measurements in the secondary displays, are shown with the last digit rounded to '0'

3.2.7 Main display

It is the main display, and it can be set to show engine RPM, spark KVolt or spark burn time by pressing the 'Main Function / Calibrate' button.

3.2.8 Functions and measurement units

Displays the measurement units and/or function of the main display. The selected function with measurement units are displayed as follows:

Display	Function	Measurement units
RPM	Tachometer	RPM (Revolutions per minute)
Burn Time mS	Spark plug burn time	mS (Milliseconds)
Spark KVolt	Spark plug peak voltage	KVolt (1000 x Volt)

3.3 Buttons description and operation

3.3.1 Power ON/OFF and Reset button



- When the instrument is OFF, to turn it ON press and hold the '*Power ON/OFF / Reset*' button until the unit turns on (in approximately 1 second).
- When the instrument is ON, to turn it OFF press and hold the '*Power ON/OFF / Reset*' button until the display turns OFF (in approximately 3 seconds).
- When the instrument is ON, press momentarily the '*Power ON/OFF / Reset*' button to reset the Maximum and Minimum and capture values.

Note: To extend battery life, the TA500 will automatically turn OFF after 3 minutes of being idle (i.e. no button pressed and no input signal). Turning the unit off manually, when not in use will prolong battery life.

3.3.2 Ignition System button



- Press the '*Ignition System*' button to select the ignition system measuring mode that matches the ignition system used in the engine being diagnosed, as explained below. The selected setting will be shown on the display.
- **SPW** (Spark Plug Wire): Use this setting for all ignition systems equipped with high voltage spark plug wires (e.g.: Conventional distributor, magneto, distributorless or waste spark ignition systems).
- **COP** (Coil On Plug): Use this setting for ignition systems in which the ignition coil is mounted near or directly on top of the spark plug.

3.3.3 Engine Cycles button



- Press the '*Engine Cycles*' button to select the number of cycles for the engine under measurement. Each time the button is pressed the number of cycles will change between 2 cycles, 4 cycles, and DIS settings. The selected setting will show on the display.
- For **SPW** (Spark Plug Wire) measurements mode, it can be set to : 2 or 4 cycles or DIS (Distributorless or waste spark ignition system).
- For **COP** (Coil on Plug) measurement mode, it can be set to: 2 or 4 cycles.

3.3.4 Main Function / Calibrate button



- Press this button to change which measurement is shown in the main (large) display. There are three measurements to choose from: RPM, spark burn time, and spark KVolt. Every time this button is pressed momentarily the measurement changes from one function to the next.
- Press and hold this button for three seconds to start the automatic calibration of the unit to the **COP** module type being measured. While calibrating, the display will flash "CAL" and will return to normal after the procedure is completed (in about 3 seconds). Calibration is disable when in **SPW** mode.

3.3.5 Secondary Function / Capture button



- Press this button momentarily to change what is displayed in the two secondary displays. There are two possible choices: the two measurements not shown in the main display or the Maximum and Minimum readings of the main display.
- Pressing and holding this button for three seconds enables 'Capture mode', which measures and holds the maximum readings. To exit this mode press the 'Secondary Function / Capture' button momentarily again.

3.3.6 Main and Secondary Functions display combinations

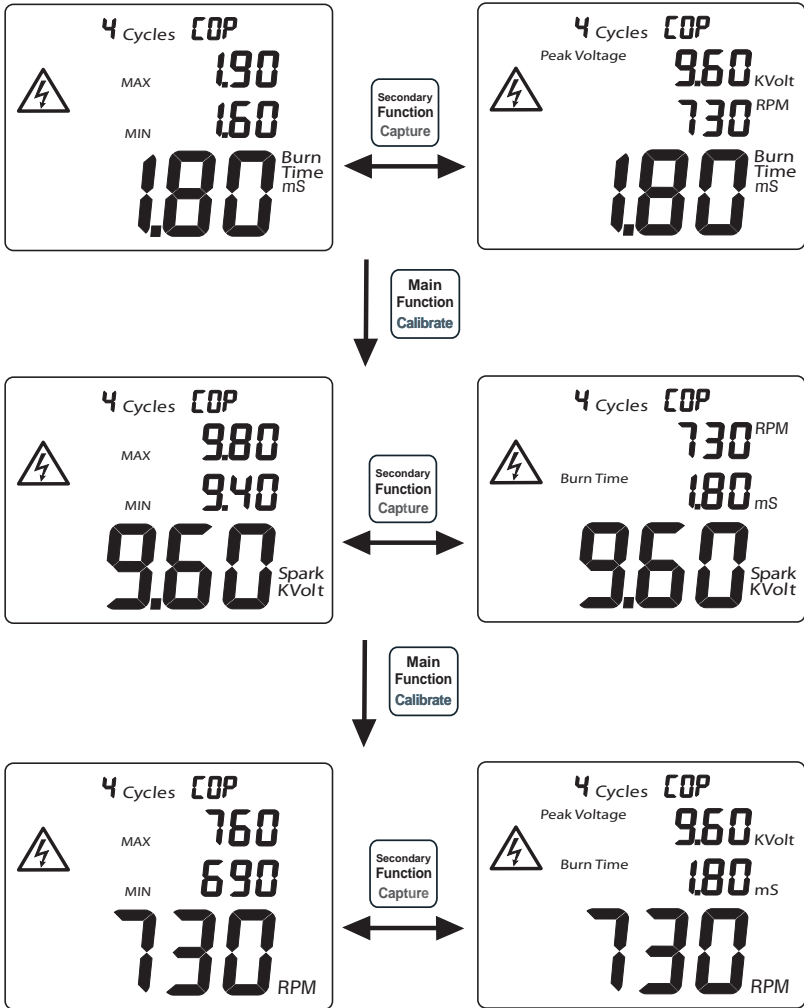

Fig. 3 - Examples of Main and Secondary Functions combinations

3.4 Measurement Procedures

CAUTION

To avoid personal injuries and damage to the instrument carefully inspect the spark plug wires, distributor cap, ignition coil, ignition module, and all other ignition system parts for damage or leaks, and avoid using this instrument in case any damage or leaks are found. Never touch the capacitive pick-up or flexible probe during a test. Wear insulating gloves when working around high voltage, and hot parts, and keep away from moving parts (fan, drive belts, etc) and hot objects (exhaust manifold and pipes, muffler, catalytic converter, etc.)

3.4.1 TA500 measuring functions

The TA500 has specially dedicated modes for use in the diagnostics and troubleshooting of Coil on Plug and Coil near Plug ignition technology, and for systems using spark plug wires. These special modes compensates for differences in signal strength and waveform patterns between ignition systems.

The TA500 can measure the following:

- Engine RPM,
- Spark burn time, and
- Spark KVolt (relative measurement).

3.4.1.1 Engine RPM

Measures engine RPM in 2, 4 cycles and DIS engines, and it can be used in combination with spark burn time and spark KVolt measurements, to evaluate the ignition system performance at different engine speeds.

3.4.1.2 Spark burn (firing) time

The spark burn time, also called “firing time”, is the measurement of the time period from the moment that a spark is initiated up to the point when it is extinguished, and is the most indicative measurement of performance of the ignition system. Abnormally long or short burn times may indicate some problem in the ignition module, spark plug, fuel mixture, cylinder compression, etc.

3.4.1.2 Spark KVolt

Spark KVolt values are relative measurements, useful to compare the performance of the ignition system in each cylinder. Comparing spark KVolt between cylinders may be used to diagnose common problems like misfires, broken spark plug wires, etc. However spark KVolt values may vary widely, are less consistent and not always indicative of a properly working ignition system.

3.4.2 Measuring Coil on Plug and Coil near Plug ignition systems

- 1-Turn the instrument on.
- 2- If not already in **COP** mode, select it by pressing the '*Ignition System*' button.
- 3- Select the number of cycles for the engine under measurement by pressing the '*Engine Cycles*' button repeatedly until the display shows the correct setting.

- 4- Select the measurement to show in the main display: RPM, spark burn time or spark KVolt.
- 5- Select the mode for the secondary display: Minimum and Maximum of the main display or the complementary measurements.
- 6- Place the capacitive pick-up (yellow tip of the probe), as shown in Fig. 4 below, over one of the ignition modules, searching for the position that produces a stable RPM or spark burn time reading.
- 7- If this is the first measurement taken in the engine, then proceed to calibrate the spark KVolt measurement first (following the procedure in '3.3.4 Main Function / Calibrate button'), as this calibration value will be used as a reference value to compare the spark KVolt reading between all the coil on plug or coil near plug modules.
- 8- Place the capacitive pick-up over the ignition modules and read the measurements in the display.

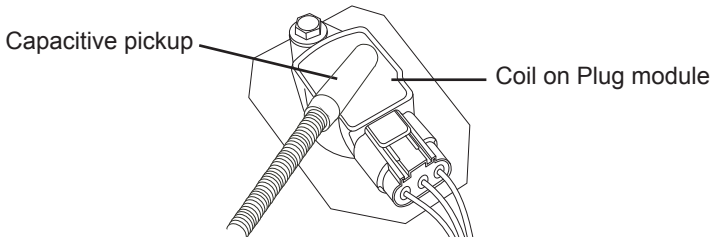

Fig. 4 - Capacitive pickup on coil on plug module

Important:

- In some engines, the ignition modules are located very close together, and this may cause the TA500's capacitive pick-up to receive signals from nearby modules, which may cause false readings.
- To reduce interference from others ignition modules, cover completely the nearby ignitions modules with pieces of aluminum foil, making sure the aluminum foil is connected to a good electrical ground in the engine (e.g. valves cover, mounting bolts).

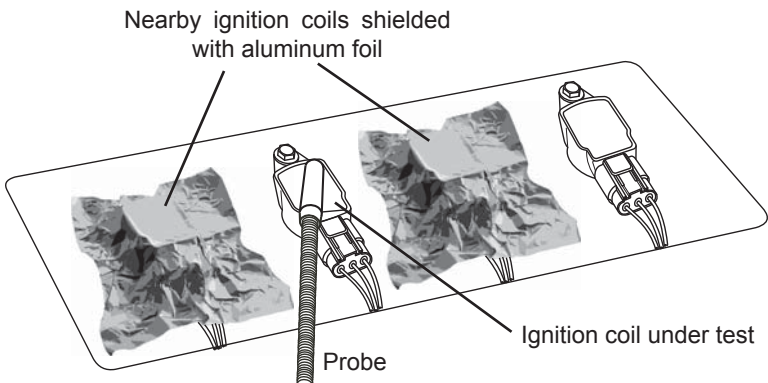

Fig. 5 - Avoiding interference by shielding nearby ignition coils

3.4.2 Spark plug wire ignition systems

- 1-Turn the instrument on.
- 2- If not already in **SPW** (Spark Plug Wire) mode, select it by pressing the '*Ignition System*' button.
- 3- Select the number of cycles for the engine under measurement by pressing the '*Engine Cycles*' button repeatedly until the display shows the correct setting.
- 4- Select the measurement to show in the main display: RPM, spark burn time or spark KVolt.
- 5- Select the mode for the secondary display: Minimum and Maximum of the main display or the complementary measurements.
- 6- Place the capacitive pickup over one of the spark plug wires, and proceed to read the measurement on the display.

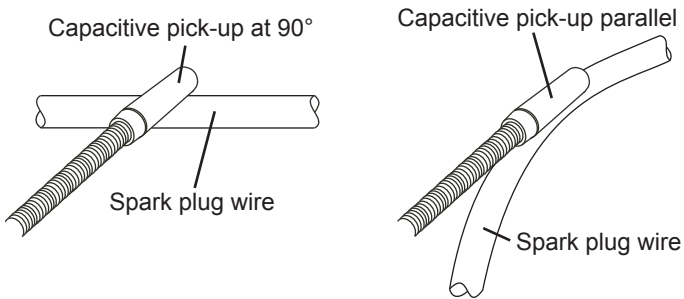

Fig. 6 - Capacitive pick-up on spark plug wire

Important:

- In order to obtain consistent results when measuring Spark KVolt on spark plug wires, the position of the capacitive pick-up relative to the spark plug wire should be the same for every measurement.
- An easy way to obtain consistent measurements, is to position the capacitive pick-up either at 90° or parallel to the spark plug wire (Fig 5), and then repeat the same positioning for every spark plug wire
- Spark burn time and RPM measurements are not sensitive to the exact position of the capacitive pick-up relative to the spark plug wire, but it has to be placed so the instrument is capable of detecting the signal.
- When several spark plug wires are routed or bunched close together, the capacitive pick-up may receive signals from several wires at the same time, which could cause erroneous measurements. In these situations it may be necessary to separate the wire under measurement from the others, in order to reduce interference and obtain an accurate measurement.

3.5 Additional functions

3.5.1 Minimum and Maximum functions (For COP and SPW modes)

The TA500 maintains a continuous record of the minimum and maximum readings of the function currently selected.

- 1-To display the Minimum and Maximum readings of the main display, if not already selected press 'Secondary Function / Capture' button momentarily.
- 2-To reset the Minimum and Maximum readings, press the 'Power On/Off / Reset' button momentarily. These values are also reset when turning the unit on.

Note: For the tachometer function (RPM) all Minimum and Maximum readings on the secondary displays are shown with the last digit rounded to "0".

3.5.2 Spark KVolt calibration function (For COP mode only)

The TA500 requires the user to calibrate the instrument in order to measure spark KVolt in Coil on Plug and Coil near Plug ignition systems. This calibration uses the measurement values obtained during the procedure to find the optimal measuring parameters or a particular type of ignition module, and compensates for differences in waveform and signal strength.

- Once the TA500 has been calibrated on one of the ignition modules of the engine being diagnosed, all the subsequent measurement of spark KVolt will be relative to the calibration value.
- To calibrate the TA500, follow the procedure as described in '3.4.2 Measuring Coil on Plug and Coil near Plug ignition systems'.

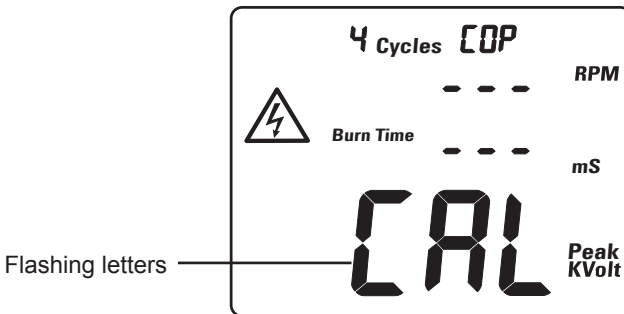

Fig. 7 - Display during calibration

Notes:

- Immediately after calibration, the TA500 will display a baseline value of "10.0 Spark KVolt" by default. All the spark KVolt measurements obtained thereafter would be relative to the (value) module used for calibration.
- Calibration does not have any effect on spark burn time or RPM measured values (these are absolute).
- If the TA500 is calibrated again, the Spark KVolt values obtained before and after calibration may not be comparable.
- If not calibrated, the TA500 may show a false '0.0 Spark KVolt' reading when measuring spark KVolt on Coil on Plug and Coil near Plug systems.

3.5.2 Capture function (For COP and SPW modes)

The capture function is used to measure and hold maximum spark KVolt and spark burn time readings. This function is most useful when performing a no-start test or when measuring ignition modules in places in which it is difficult to position the capacitive pick-up over the module and read the display at the same time.

To use the capture mode:

- 1-Follow the directions in '3.4 Measurement Procedures', to setup the TA500.
- 2-Press and hold the 'Secondary Function / Capture' button (for approximately 3 seconds) until a flashing "CAP" appears in the secondary display A.
- 3-To exit the capture mode, press the 'Secondary Function / Capture' button momentarily again.

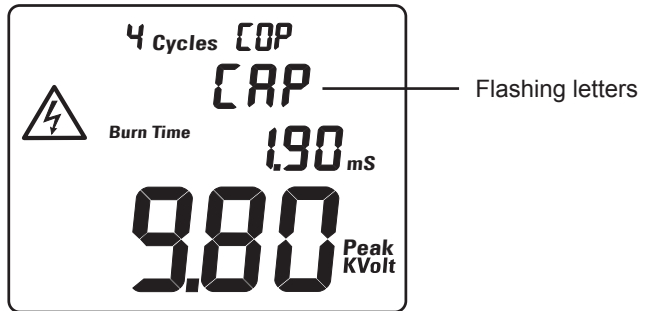

Fig. 8 - Typical display in capture mode

Notes:

- The capture function holds the maximum spark KVolt and spark burn time displayed (measured) values.
- The values held while in capture mode can be reset by pressing the 'Power ON/OFF / Reset' button momentarily.
- When in capture mode, only the 'Power ON/OFF / Reset' and 'Secondary Function / Capture' buttons will remain operative, in order to prevent accidental changes in the setup of the TA500.
- Upon exiting the capture mode, the held values are reset.

3.5.3 Auto power off

To help prolong battery life, the TA500 will automatically turn off after a period of approximately 3 minutes of inactivity.

A period of inactivity means:

- No buttons are pressed
- No measurements are taken

4. APPLICATION INFORMATION

4.1 Taking measurements

- 1-Select the ignition system to measure following the instructions in in '3.4 Measurement Procedures'.
- 2-Observe the spark burn time and spark KVolt reading of the display. Some variations of the readings are normal and reflects actual changes in the spark voltage and burn time in the ignition system.
- 3-Record or memorize the maximum, minimum and average reading. Repeat the test for each of the spark plug wires or ignition modules of the engine and note any readings that are significantly higher or lower than the average.
- 4-Ignition problems may sometimes appear at higher engine RPM, but not at low or idle speed. We recommend that measurements be made at idle speed and normal engine operating temperature, and then at increasing RPM, and up to equivalent of highway speeds, typically about 2000 to 2500 RPM. Do not exceed maximum permissible ("red-line") engine speeds. Make all measurements at about the same engine speeds, using the TA500 tachometer function to check the RPM.

4.2 Diagnostic using spark burn time and spark KVolt readings

Small variations in spark burn time and spark KVolt readings from cylinder to cylinder are normal, and do not indicate any problem.

For diagnostic purposes, the attention should be focused on SIGNIFICANT DIFFERENCES in readings, most likely caused by problems in the engine or the ignition system itself.

Important:

- The RPM and spark burn time displayed by the TA500 are absolute measurements.
- Spark KVolt is a relative measurement and should be used only to compare between ignition modules or spark plug wires in the same engine.
- In COP mode, always perform a calibration of the spark KVolt in one of the ignition modules as described in '3.4.2 Measuring Coil on Plug and Coil near Plug ignition systems' before proceeding to measure and compare results between cylinders.
- When measuring on spark plug wires (SPW mode) the placement of the capacitive pick-up along the spark plug wire will also cause some variation, due to the internal resistance (or impedance) of the spark plug wire. For example, if the capacitive pick-up is placed on the spark wire near the distributor or the DIS coil, voltage reading will be higher than if placed near the spark plug.

4.3 Common causes of long burn time readings

- Shorted, dirty or too small spark plug gap.
- Dirty or damaged spark plug insulator or boot allowing spark "tracking" across insulator.
- Rich mixture. Most likely due to leaking fuel injector, or faulty oxygen sensor.
- Low cylinder compression pressure. Could be caused by leaking valves, worn piston rings, blown cylinder head gasket, etc.

4.4 Common causes of short burn time readings

- Spark plug worn or gap too wide.
- Spark plug connector damaged, loose or disconnected.
- Excessive resistance in the ignition coil primary circuit.
- Lean mixture.

4.5 Common causes of low spark KVolt readings

- Shorted, dirty or too small spark plug gap.
- Dirty or damaged spark plug insulator boot allowing spark “tracking” across insulator.
- Broken core in spark plug wire. Break is located between the distributor (or DIS coil) and the test point.
- Short circuit, disconnection or partial disconnection between the distributor (or DIS coil) and spark plug wire.
- Rich mixture. Most likely due to leaking fuel injector, or faulty oxygen sensor.
- Low cylinder compression pressure. Could be caused by leaking valves, worn piston rings, blown cylinder head gasket, etc.

4.6 Common causes of high spark KVolt readings

- Spark plug worn or gap too wide.
- Spark plug connector damaged, loose or disconnected.
- Broken core in spark plug wire. Break is located between the spark plug and the test point.
- Lean mixture.

5. MAINTENANCE

2.1 Battery replacement

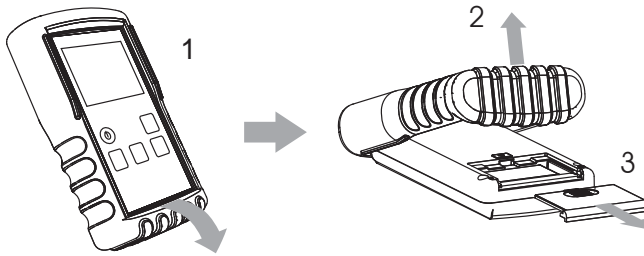

Fig 9 - Battery replacement

To replace the internal battery:

- 1-Release the rubber holster from plastic enclosure by pulling from the bottom of the holster as shown in the illustration (Fig. 9)
- 2-Push the rubber holster forward until the battery compartment cover is exposed.
- 3-Slide open battery cover located at the back of the unit.
- 4-Connect the new battery observing the polarity of the battery connectors.
- 5-Replace battery cover and rubber holster.
- 4-Press the '*Power On/Off / Reset*' button on the TA500 until the display turns on. If the display does not turn on, check the battery polarity and reinstall if necessary. To turn the unit off, press and hold the '*Power On/Off / Reset*' button again until the display turn off.

5.2 Cleaning

Keep the instrument in its carrying case when not in use and do not subject it to dampness or severe heat or cold. Do not use the instrument in the rain, if it should accidentally get wet, dry it off with a clean paper towel before storing it away.

Protect the unit from contact with any solvents. Never clean with a solvent or petroleum based medium such as gasoline, as these chemicals may attack the plastic parts and cause permanent damage. Never use an abrasive cleaner. Cleaning should be limited to wiping with a clean damp paper towel and a small amount of soap if required. Dry the unit thoroughly after any cleaning.

The unit is a sealed instrument and contains no user serviceable parts other than the battery, which can be replaced by opening the drawer on the back of the unit. Opening other parts of the unit will void the warranty.

6. WARRANTY

With the exception of the battery, this instrument is warranted against defects of material or workmanship which develop within a period of one (1) year following the date of purchase by the original owner. For details see our Standard Warranty Information on our web page at www.gtc.ca or you may request a printed copy.

To visit our website, scan the QR code below with your smart phone.



Or type this URL in your browser:

www.gtc.ca

GTC
General Technologies Corp

#121 - 7350 72nd Street
Delta, BC
Canada V4G 1H9

Tel: (604) 952-6699
Fax: (604) 952-6690
email: info@gtc.ca